



PROMASTER[®]
7500DX Digital

OPERATING INSTRUCTIONS

ELECTRONIC FLASH

• TWIN FLASH • BOUNCE • SWIVEL • MOTORIZED ZOOM

FOR CANON (CN)

PARTS IDENTIFICATION

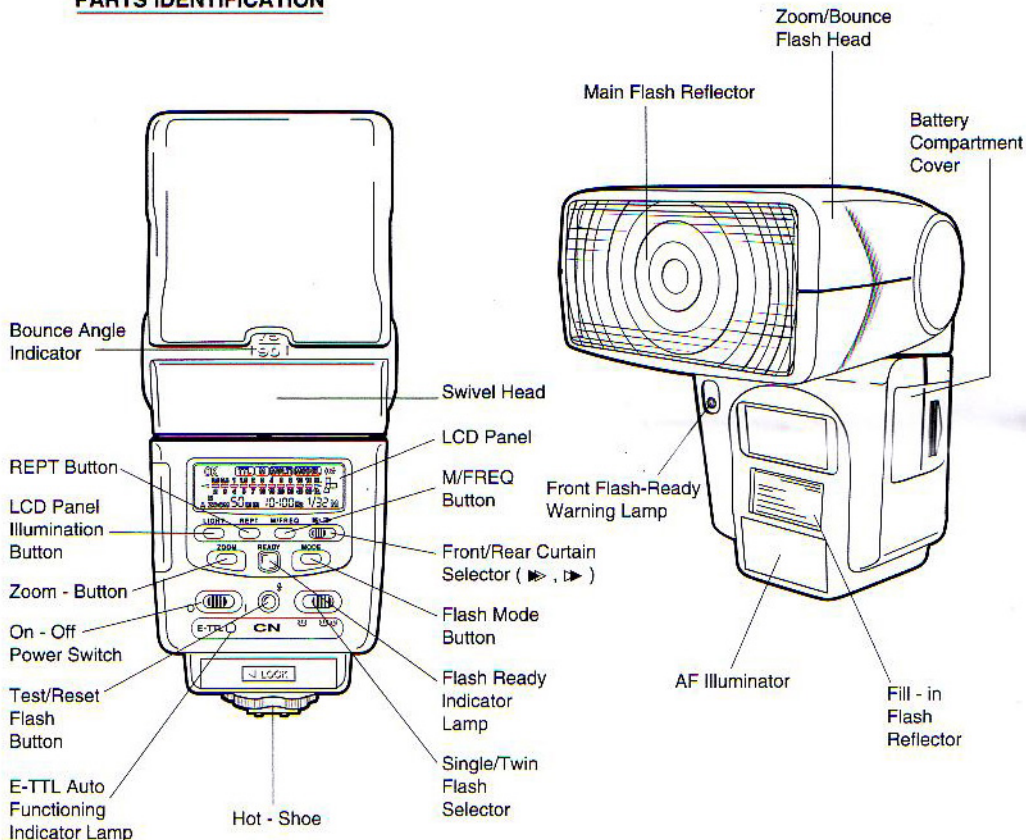

FLASH DEDICATION

This flash unit - CN is dedicated to work with the CANON current digital cameras and other EOS 35mm SLR autofocus cameras. It incorporates the E-TTL evaluative pre-stored flash exposure control system with the FE lock capability for full automatic flash photography. It reverts to standard TTL auto operation when used with older CANON EOS cameras.

- This flash is dedicated to work with compatible cameras only.
- As different models of cameras operate differently for flash photography, you should read the Instruction Manual of your cameras for details of flash operation.

LCD DISPLAY

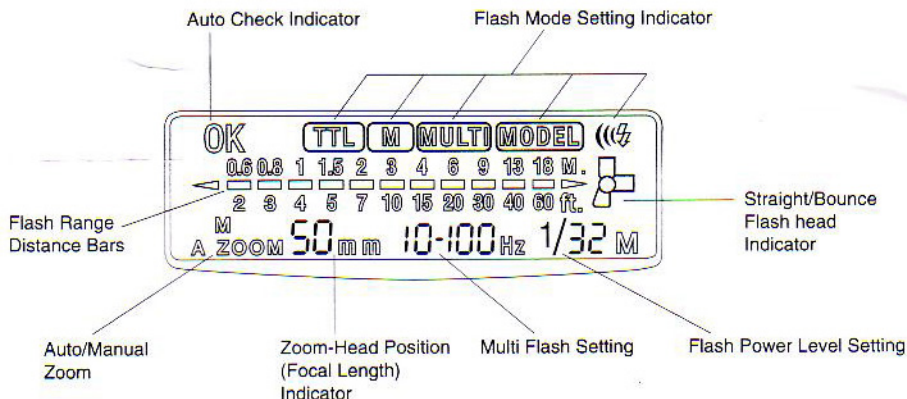

- In TTL Autoflash or MANUAL mode, Flash Range Distance bars appear when the flash unit is mounted on the mating camera.

E-TTL AUTO FLASH OPERATION WHEN USED WITH DIGITAL CAMERAS

This flash unit is fully digital E-TTL compatible and is controlled entirely by the camera, based on the information sent from it. Available light is metered through the camera's lens and illumination is set automatically.

- Notes:
- All flash exposure settings are in the camera's Control Menu
 - You can not use an external flash and the built-in flash at the same time.

BATTERY OPERATION

1. Open the battery compartment cover.
2. Insert four 1.5 V penlight batteries following the (+) (-) sign as indicated inside and replace the cover.

IMPORTANT:

- THE BATTERIES SHOULD BE INSERTED IN CORRECT POSITION.
- FOR BEST RESULTS, USE ALKALINE BATTERIES.
- USE FRESH BATTERIES REGULARLY.
- DO NOT MIX FRESH AND WEAK BATTERIES.
- TO PREVENT BATTERY LEAKAGE, REMOVE BATTERIES IF STORING FOR LONG PERIODS.

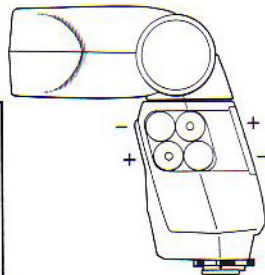

AF ILLUMINATOR FOR AUTOFOCUSING

When subject contrast is low or in low light, the AF illuminator is automatically activated when the camera's shutter release button is pressed halfway. This illumination enables the camera's autofocus system to focus correctly.

The AF illuminator enables autofocusing with subjects up to about 16 feet away. This working range of the AF illuminator is based on standard testing method with a 50 mm lens.

- The AF illuminator may not be effective if your subject has very low reflectance.

AUTO POWER-OFF

A battery-saving automatic power-off circuitry is incorporated in this flash unit. If you do not operate any of the flash or camera controls for about five minutes, the flash-ready lamp will be automatically extinguished and the LCD data panel will be switched off. The flash unit will be in stand-by mode. To re-activate the flash, simply press lightly the camera's shutter button or the flash's test button or switch the flash unit to OFF and then ON again. In slave flash mode, the off-camera flash will be switched off automatically if you do not use it for about one hour.

AUTO CHECK

When using the flash unit in TTL Autoflash mode, if exposure was sufficient, the auto check indicator "OK" will appear in the LCD panel at the same moment when the camera's shutter button is pressed.

FLASH MODE

This unit has five firing flash modes : TTL, M, MULTI, MODEL and (($\frac{Q}{Z}$) (Slave).

You can select the desired mode by pressing the 'MODE' button. Each press of the Mode button changes the flash mode in the following cycle :

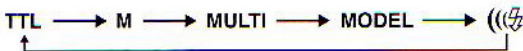

- As different models of camera operate differently for flash photography, you should read the Instructions Manual of your camera for details of flash operation.

A. TTL AUTOMATIC FLASH OPERATION

TTL

The flash unit provides automatic Through-The-Lens (TTL) control of the flash exposure when used with the mating cameras which have TTL auto flash metering feature. It is fully E-TTL compatible (E-TTL functioning indicator lights) when used on digital cameras and EOS 35mm SLR autofocus cameras with E-TTL autoflash metering system.

The TTL autoflash mode balances the exposure between the main subject illuminated by the flash and the background in ambient light, whenever possible. Thus, this TTL mode can be used under conditions ranging from darkness to fill-in flash.

(● When demonstrating TTL Auto Flash function, there must be film inside the film SLR camera.)

a. Program TTL Autoflash Mode

1. Set the camera's shooting mode to full auto program mode and the flash unit's mode to 'TTL'.
2. Press the shutter button halfway to focus the subject.
3. When the flash-ready indicator lights, the camera will automatically set the aperture and shutter speed values.

b. Shutter-Priority TTL Autoflash Mode

1. Set the camera's shooting mode to shutter-priority mode and the flash unit's mode to 'TTL'.
2. Set a desired shutter speed. If a shutter speed faster than X-sync time is selected, the camera will automatically switch to the X-sync time when the flash is ready. You can select slower shutter speeds.
3. Press the shutter button halfway to focus the subject and confirm that the distance from the camera to the subject is within the autoflash range displayed in the LCD panel.
4. When the flash-ready indicator lights, the camera automatically sets the aperture.

c. Aperture-Priority TTL Autoflash Mode

1. Set the camera's shooting mode to Aperture-Priority mode and the flash unit's mode to 'TTL'.
2. Set a desired aperture value. This enables you to have greater control over depth of field.
3. Press the shutter button, halfway to focus the subject and confirm that the distance from the camera to the subject is within the autoflash range displayed in the LCD panel.
4. When the flash-ready indicator lights, the camera will automatically sets the shutter speed.

d. Manual TTL Autoflash Mode

For back-lit subjects, or in low light situations, slower shutter speed can be set to increase the background exposure while maintaining normal exposure of the main subject. This is helpful for filling in shadows and balancing out the lighting situation.

1. Set the camera's mode to manual mode and set the flash unit's mode to 'TTL'.
2. Set the camera's shutter speed and the desired aperture manually.
 - If a shutter speed faster than X-sync time is selected, the camera will automatically switch to the X-sync time when the flash is ready. You can select slower shutter speeds.
3. Press the shutter button halfway to focus the subject and confirm that the distance from the camera to the subject is within the autoflash range displayed in the LCD panel.

B. MANUAL FLASH OPERATION



1. Set the camera's shooting mode to manual mode and set the flash unit's mode to 'M'.
2. Press the 'M/FREQ' button to select a desired output level.
Each press of the 'M/FREQ' button changes the flash output level in the following cycle:

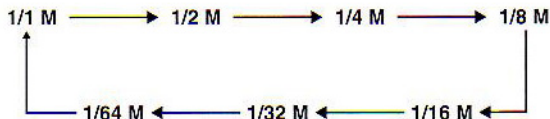

3. Manually set the camera's shutter speed to X-sync speed or slower and set the desired aperture and then take the picture after confirming that the subject is within the flash range displayed in the LCD panel with a distance indicator bar.

C. MULTIPLE FLASH OPERATION

MULTI

With multiple flash mode, the flash unit can be fired several times in succession during a single exposure to record the flowing motion of a subject. It is recommended to operate the main flash only (by sliding the sub-reflector switch to ζ position).

1. Set the flash's mode to 'MULTI'.
2. Press the 'REPT' button to select the number of times the flash will fire.



3. Press the 'M/FREQ' button to select the firing frequency in HZ (flashes per sec.)

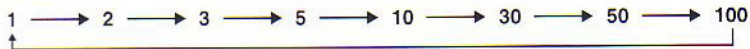

4. Set the camera to Manual mode and set the desired aperture and the shutter speed calculated from the following formula:

No. of bursts \div Firing Frequency

For example: 10 - 5 HZ The shutter speed should be 2 (10 \div 5) sec or longer

- When using the Multi flash mode, the flash power level is automatically set to 1/16M and can not be changed.
- A distance indicator bar appears in the flash range display. This is the distance at which one burst from the entire sequence will provide a correct exposure.

D. MODELING FLASH OPERATION

MODEL

This feature helps you to view the effects of the flash's position in relation to your main subject before you take the picture. It is recommended to operate the main flash only (by sliding the sub-reflector switch to ζ position).

1. Set the flash's mode to 'MODEL'.
2. Press the 'M/FREQ' button to select H-F or L-F.

High Frequency (H-F) : A high-frequency series of low-power pulses that is most useful when you take close-up pictures.

Low Frequency (L-F) : A low-frequency series of strong flash bursts for use when taking portraits or whenever your subject is large.

3. Press the flash's Test button to activate the modeling flash.

- In this Modeling flash mode, the flash range display in the LCD panel will disappear.

E. SLAVE FLASH OPERATION



- It is recommended to operate the main flash only (by sliding the sub-reflector switch to ☞ position).

The flash unit can be used as a slave flash unit (a flash-stand is provided), which will fire when its wireless Slave Flash sensor catches light from the master flash unit. You can select the flash power level by pressing the 'M/FREQ' button when the flash unit's mode is set to ☞.

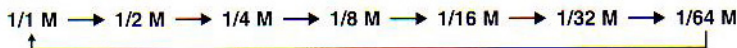

- In this slave flash mode, the flash range display in the LCD panel will not appear.
- When used for the slave flash operation, the flash unit is operated in manual mode.

F.E. LOCK

When used on capable cameras with the E-TTL metering system, this flash unit enables FE (flash exposure) lock. This is the flash version of AE lock. With FE lock, you use the spot metering to obtain and lock the correct flash exposure reading for a specific part of the subject. You can then recompose the shot while retaining the flash exposure reading.

1. Set the camera to a picture-taking mode and focus the subject.
 2. Aim the focusing point where you want to obtain the correct flash exposure reading, then press the FE lock button < * > or < FEL > on the camera. The flash fires a pre-flash to obtain an exposure reading which is then locked (retained in memory) for 16 sec.
 3. Recompose and take the picture within 16 sec.
- FE lock can be used only on the E-TTL flash mode.
 - Using FE lock may not make any difference for a small subject.
 - The FE lock is cancelled when 16 sec elapse or when the camera's Command Dial (Mode Dial) is turned.

WIDE-ANGLE DIFFUSER – A wide-angle Diffuser accessory that can be positioned in front of the zoom flash head is included in this flash unit's package. The flash can cover 17mm wide-angle lens on a 35mm SLR camera when the zoom flash head is set at 24mm with the included Diffuser.

17mm
(24mm + Diffuser)

Flash Coverage
75° Vertical
92° Horizontal

Guide Number (at ISO100)
46 feet (Single main flash)
42 feet (Dual flash)

FLASH COVERAGE ANGLE

Coverage angles are available for focal length ranging from 24 mm to 105 mm (based on a 35mm SLR camera).

● AUTO ZOOM OPERATION (A ZOOM)

If this facility is not supported by your camera, use the Manual Zoom operation.

The flash unit automatically adjusts the zoom-head position to provide angle of coverage that matches the focal length of the lens in use and the setting is displayed in the LCD panel. The coverage angle automatically changes when the lens is zoomed.

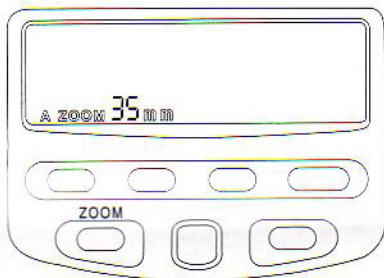

- The guide number changes when the flash coverage angle is changed.
- If the focal length of the lens in use is less than 24 mm, only "A Zoom 24 mm" will be displayed. If the focal length of the lens in use is larger than 105 mm, only "A Zoom 105 mm" will be displayed.
- If ^MZoom is displayed in the LCD panel, press the Zoom button until "A ZOOM" is displayed.





● MANUAL ZOOM OPERATION (^MZoom)

Press the Zoom button once to change from auto zoom to manual zoom mode. Each press of the Zoom button changes the coverage angle in the above cycle. Press zoom button until your desired zoom-head position appears in the LCD panel.

Note: The digital camera lenses require shorter focal lengths to obtain the same angle of coverage as their 35mm counterparts. (e.g. The 18-55mm f3.5-5.6 Canon EF-S zoom lens on the EOS digital Rebel is approximately equivalent to a 29-88mm lens on a 35mm SLR)

BOUNCE PHOTOGRAPHY

Bounce lighting involves 'bouncing' the light off a ceiling or other reflective surfaces to obtain soft illumination. The flash head can be rotated both vertically and horizontally to achieve the optimum bounce position. (The flash has click stops at the most commonly used position). It is recommended to operate your flash unit in TTL mode.



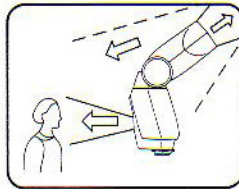
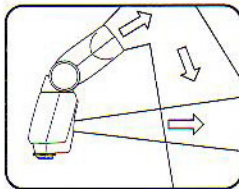
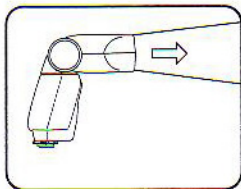

- when the flash head is at a bounce or swivel position, the flash range display will disappear and an indicator  will appear in the LCD panel.
The flash range display and  will reappear when the flash head is at straight flash (0° bounce and 0° swivel) position.

DUAL FLASH LIGHTS

You can enjoy dual flash lights with the sub-reflector. Slide the sub-reflector switch to "☞" position. Dual flash light - from the main and sub-reflectors will give you a variety of flash techniques as illustrated. If you do not want to use the sub-reflector, slide the sub-reflector switch to ☞ position. It is recommended to operate double flashes for bounce flash operation. Single flash is desirable for direct straight flash.



REAR-CURTAIN SYNCHRONIZATION

When using with some models of cameras which are capable of rear-curtain sync, you can select (by sliding the switch to  or ) whether to have the flash fire as soon as the shutter opens ( - front curtain sync.) or immediately before the shutter closes ( - rear curtain sync.)

- Use shutter-priority auto or manual exposure mode.
- In MULTI flash mode, the rear-curtain sync. can not function.

(Please refer to your camera's Instructions Manual for more information.)

SPECIFICATIONS:

Power Source	: 4 (1.5V) 'AA' Alkaline Batteries or NiMH AA Rechargeable Batteries
Recycling Time	: 0.3 - 10 sec
Battery Life	: Approx. 100 - 700 flashes (Depends on the type of batteries and distance)
Flash Duration	: 1/30,000 to 1/1,000 sec.
Colour Temperature	: Same as sunlight during day
Bounce Angle	: -7° - 90° (Clip stops: -7°, 0°, 45°, 60°, 75°, and 90°)
Swivel Angle	: 0° - 180° (Clip stops: Right 0°, 30°, 60°, 90°, 120°, 150° Left 0°, 30°, 60°, 90°, 120°, 150°, 180°)
Power Zoom	: Motorized Zoom 24-28-35-50-70-80-105 focal length (mm)
Flash Coverage	: (based on a 35mm SLR camera)

	17mm (24mm+Diffuser)	24mm	28mm	35mm	50mm	70mm	80mm	105mm
Verticle	75°	60°	53°	45°	34°	26°	23°	20°
Horizontal	92°	78°	70°	60°	46°	36°	31°	27°

Note: The digital camera lenses require shorter focal lengths to obtain the same angle of coverage as their 35mm counterparts.

Guide Number (at ISO100 in feet) for Single Main Flash Only:

Power Level	FLASH COVERAGE SETTING							
	17mm (24mm+Diffuser)	24mm	28mm	35mm	50mm	70mm	80mm	105mm
1/1	46	75	85	98	112	125	130	138
1/2	32	53	60	70	79	88	92	98
1/4	23	38	43	49	56	62	65	69
1/8	16	27	30	35	39	44	46	49
1/16	12	19	21	25	28	31	33	34
1/32	8	13	15	17	20	22	23	25
1/64	6	10	11	12	14	16	16	17

Guide Number (at ISO100 in feet) for Dual Flashes :

Power Level	FLASH COVERAGE SETTING							
	17mm (24mm+Diffuser)	24mm	28mm	35mm	50mm	70mm	80mm	105mm
1/1	42	69	75	90	102	112	115	122
1/2	30	49	53	64	72	79	81	86
1/4	21	35	38	45	51	56	58	61
1/8	15	25	27	32	36	40	41	43
1/16	11	18	19	23	26	28	29	31
1/32	7	13	14	16	18	20	21	22
1/64	5	9	10	12	13	14	15	16

TTL Autoflash Range in feet (for Single Main Flash Only)

ISO FILM SPEED								FLASH COVERAGE SETTING						
25	50	100	200	400	800	1600	17mm (24mm+Diffuser)	24mm	28mm	35mm	50mm	70mm	80mm	105mm
		1.4	2	2.8	4	5.6	5 - 33	7 - 54	7 - 61	10 - 70	12 - 80	12 - 89	12 - 93	12 - 99
	1.4	2	2.8	4	5.6	8	4 - 23	6 - 38	6 - 43	6 - 49	8 - 56	10 - 63	10 - 65	10 - 69
1.4	2	2.8	4	5.6	8	11	3 - 16	5 - 27	5 - 30	5 - 35	7 - 40	9 - 45	9 - 46	9 - 49
2	2.8	4	5.6	8	11	16	2 - 12	4 - 19	4 - 21	4 - 25	5 - 28	6 - 31	6 - 33	6 - 35
2.8	4	5.6	8	11	16	22	2 - 8.2	3 - 13	3 - 15	3 - 18	3 - 20	5 - 22	5 - 23	5 - 25
4	5.6	8	11	16	22	32	2 - 5.8	2 - 9.4	2 - 11	3 - 12	3 - 14	5 - 16	5 - 16	5 - 17
5.6	8	11	16	22	32		2 - 4.2	2 - 6.8	2 - 7.7	3 - 8.9	3 - 10	4 - 11	4 - 12	4 - 13
8	11	16	22	32			2 - 2.9	2 - 4.7	2 - 5.3	3 - 6.1	3 - 7	4 - 7.8	4 - 8.1	4 - 8.6
11	16	22	32				2 - 2.1	2 - 3.4	2 - 3.9	3 - 4.5	3 - 5	4 - 5.7	4 - 5.9	4 - 6.3

The specifications are based on the latest information available at the time of printing and are subject to change without notice.